

BÄRO AirStream air-conditioning duct module



element is a radiation chamber, the dimensions of which can be adapted exactly to the existing or planned ventilation channels. The UV-C low-pressure emitters located in the radiation chamber emit light with a wavelength of 253.7 nm and produce no ozone. When air is routed past them, this radiation has a lethal effect on microorganisms.

A special interior coating of the quartz glass ensures an exceptionally long service life with minimal decline in radiative power.

System solutions for all applications

Depending on the customer's requirements, a module of this type can be set up for disinfection rates of up to 99.9%. This guarantees optimum production or storage parameters for all areas of use.

Project planning

Each module is tailored to the specific requirements of the respective project. Microbiological measurements (qualitative and quantitative) and the physical parameters are included in the calculations, thus guaranteeing economic operation.



Air as a transport medium

Our air contains many substances, such as nitrogen and oxygen, dust, exhaust gases and microorganisms such as bacteria, yeasts, fungi and their spores. The latter are key factors in the spoilage of food and use air as their transport medium. The reduction of airborne germs in rooms therefore plays a key part in lengthening the shelf life of all kinds of products and maintaining their quality.

AirStream is a module developed by BÄRO for installation in air-conditioning and ventilation systems. This system can be planned into future ventilation systems or retrofitted in existing systems.

Procedure

The AirStream air duct module is made of galvanised sheet metal or, optionally, stainless steel. The main

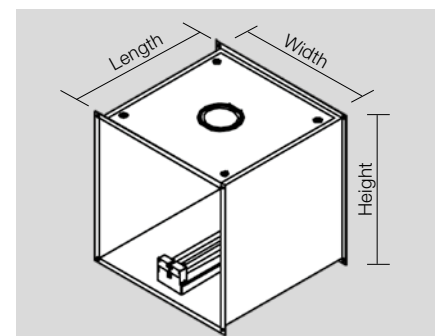

Technical description	AirStream
Width	300 – 2.000 mm
Length	600 – 2.500 mm
Height	300 – 2.000 mm
Supply voltage	230 V ~ 50 Hz
Number of UV-C emitters	Max. 80 pcs.
UV-C emitters	55 Watt 60/95 Watt compact
IP protection class	IP 65 or IP 20
Emitter service life	8,000 hrs.
Functional check	Serial interface (optional)

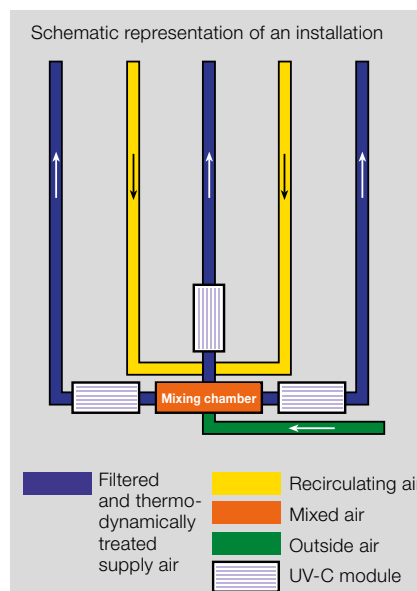

Wolfstall 54-56 · 42799 Leichlingen
 Phone + 49 2174 - 799-505
 Fax + 49 2174 - 799 799
 baero-technology@baero.com
 www.baero.com